

PORTABLE HIGH PRESSURE GAS BOOSTER PACK

type RBS

Resato's portable gas booster pack type RBS is designed to compress gas up to 1300 bar.

Not only can it be used to pressurize valves, fittings, hoses, piping, vessels and wellhead equipment, but it is also suitable for gas supply for cylinders, presses and actuators. Compressed air used as a power drive offers advantages over use of other drives. The risk of excessive heat, flame, spark or shock are reduced considerably.

The RBS as a standard is available in 8 pressure ranges with a single-acting, double-acting or two-stage gas booster. As an option, the system can be fitted with a chart recorder and a USB data acquisition system. The resulting chart can be used as a test certificate.

BOOSTER

The unique design of the Resato high pressure air-driven booster makes the compressor operate at a low noise level. The boosters are used for pressure testing with gases, industrial gas process feeds, gas charging of accumulators and gas bottles, and other applications. The high-pressure seals can be replaced without disassembling the complete booster.

ORDERING CODE

See ordering system in this document

☎ +31 (0) 50 501 6877
✉ hpsales@resato.com
🌐 www.resato.com



KEY FEATURES

- Portable
- Modular design
- Suitable for a wide range of gases
- Panel mounted operating features
- Proven reliability under severe conditions

KEY SPECIFICATIONS

- Pressures up to 1300 bar / 19,000 psi
- Long working life of seals
- Stainless steel frame
- Atex version available
- Low noise level

PORTABLE HIGH PRESSURE GAS BOOSTER PACK

type RBS

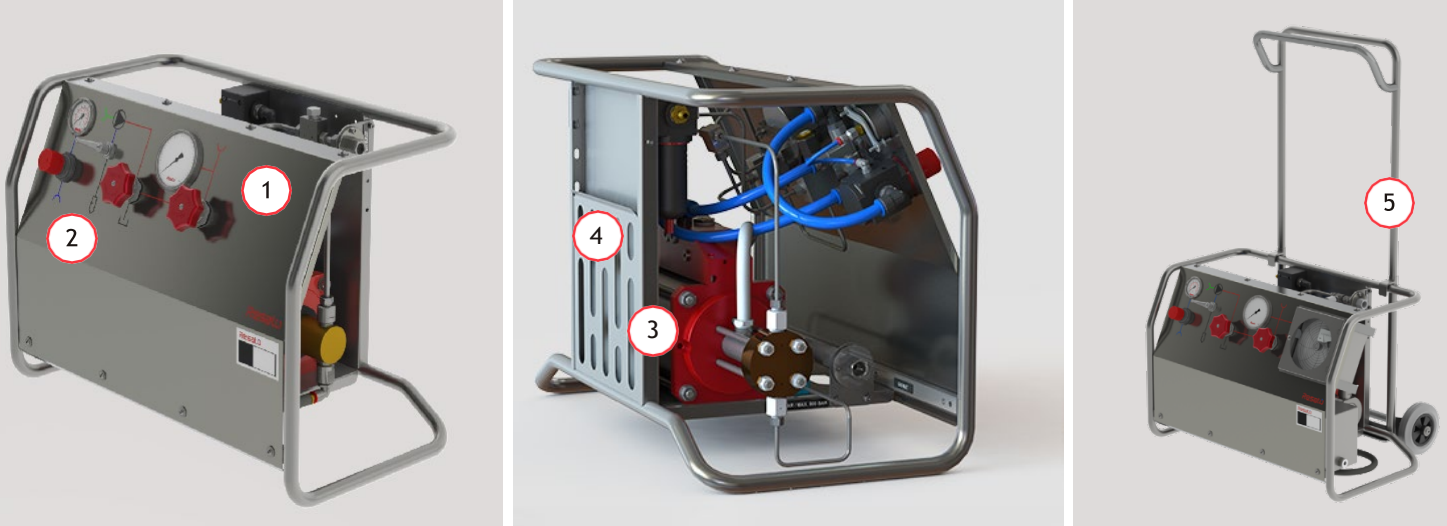

ITEM	DESCRIPTION
1	Front panel (can be equipped with recorder)
2	Engraved flow diagram
3	Atex earth connection
4	Document holder
5	Pushbar with hose bracket (accessory/optional)

PORTABLE HIGH PRESSURE GAS BOOSTER PACK

type RBS

FLOW CHARTS

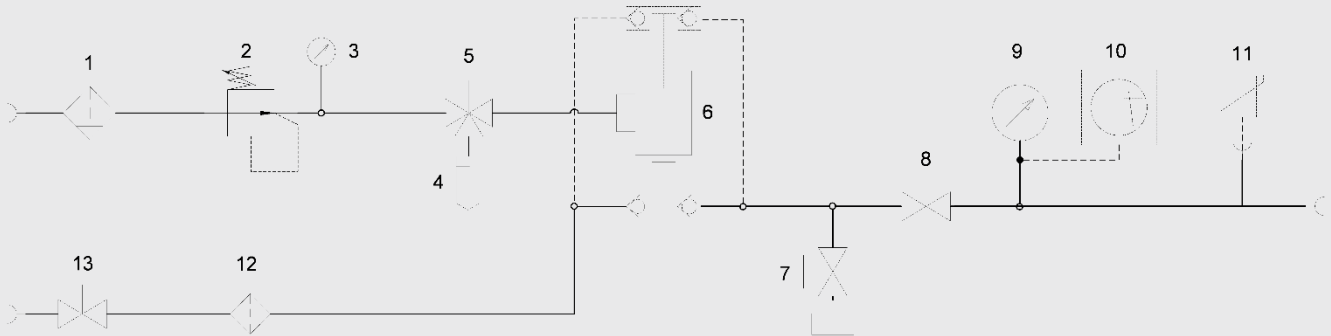

- | | | |
|------------------------------|-------------------------|-------------------------------------|
| 1. Air filter | 6. Gas booster | 11. Pressure transmitter connection |
| 2. Supply pressure regulator | 7. Bleed valve | 12. Inlet filter |
| 3. Air pressure gauge | 8. Isolate valve | 13. Direct feed valve |
| 4. Silencer | 9. Pressure gauge | |
| 5. Three way ball valve | 10. Recorder (optional) | |

PORTABLE HIGH PRESSURE GAS BOOSTER PACK

type RBS

SYSTEM DESCRIPTION

MATERIALS

All components such as valves, tubing, fittings and gauges are made of stainless steel. Just like the frame and optional pressure recorder. The seals are made of Teflon (valve), Viton (check valves) and U-PE for the high pressure piston seals. Other seal materials and special seals are available.

OUTLET PRESSURE GAUGE

Class 1.0% F.S., housing \varnothing 100 mm (4 inch), fully stainless steel, filled with glycerin and fitted with laminated safety glass.

AIR PRESSURE GAUGE

Range 0-10 bar/0-140 psi class 1.6% F.S., housing \varnothing 63 mm (2.5 inch) fully stainless steel, filled with glycerin and fitted with laminated safety glass.

CERTIFICATION

The Resato portable gas booster pack is supplied with a system test certificate, a calibration report for the test gauge and optional recorder, and an operating and maintenance manual.

AVAILABLE OPTIONS

PNEUMATIC HIGH PILOT VALVE

A pneumatic high pressure valve will stop the booster when the maximum set pressure is reached. The pressure set point is adjustable.

PNEUMATIC LOW PILOT VALVE

A pneumatic low pressure valve will stop the booster when the supply pressure is too low. This will prevent damage to the booster due to a too low gas supply pressure.

SUPPLY PRESSURE REGULATOR

The supply pressure regulator prevents stalling of the two stage gas booster in case of a high gas supply pressure. The regulator is provided with a pressure gauge and the inlet is mounted. Maximum inlet pressure is 250 bar. An additional option is to include a bypass pre-fill line with check valve and pressure relieve valve.

GAS SUPPLY GAUGE

Range 0-600 bar/0-8,700 psi, class 1.0% F.S., housing \varnothing 63 mm (2.5 inch) fully stainless steel, filled with glycerin and fitted with laminated safety glass. A calibration certificate is included.

PORTABLE HIGH PRESSURE GAS BOOSTER PACK

type RBS

CONSTANT PRESSURE CIRCUIT

A high pressure regulator is used to reach a constant and stable output pressure. When a double acting or two stage booster is used, the system depends less on variable inlet pressure. The maximum supply pressure is 400 bar/5,800 psi. The maximum working pressure is 690 bar/10,000 psi. A outlet pressure gauge \varnothing 100 mm (3.9 inch) is included.

COMMON LEAK HOLE CONNECTION

The leak holes of the high pressure seals are connected on a common drain outlet connection.

PC DATA ACQUISITION AND RECORDING SYSTEM

Documentation of test results is very important. For that purpose Resato offers a plug and play PC data acquisition and recording system (type RCR-USB). The sytem converts Resato USB pressure transmitter signals into real-time pressure measurement and generates a test certificate with a graph immediately after completion of a test.

ATEX

Resato air-driven boosters can be delivered in a version that complies with ATEX/94/9/EC. The boosters are ATEX approved for Group II, category 2 zones G & D.

PORTABLE HIGH PRESSURE GAS BOOSTER PACK

type RBS

TYPE ORDERING SYSTEM

System	Booster	Ratio	Flow*	Gauge range	HP outlet connection
RBS	160	5	(1 <i>Single acting</i>) 2 <i>Double acting</i>	D (dual scale)	B

* in case of two-stage an additional ratio number is added

Order example single or double acting: **RBS-160-5-2-D-B**
 Order example two-stage acting: **RBS-160-5-30-D-B**

TYPE TABLE

RBS 160 booster

* tba = to be advised

Booster	Flow type	Ratio	Max. outlet pressure		Stroke volume	Gauge range* (Dual scale)		HP outlet connection
			bar	psi		psi	bar	
160	Single acting	2.5	18	260	785 cc	tba		1/2" NPT-F
		5	35	510	385 cc	tba		1/2" NPT-F
		10	70	1,015	200 cc	1500	100	1/2" NPT-F
		15	115	1,670	125 cc	tba		1/4" NPT-F
		30	200	2,900	70 cc	4000	275	1/4" NPT-F
		40	285	4,130	50 cc	6000	410	M16x1.5 HP-F
		65	450	6,450	30 cc	10,000	690	M16x1.5 HP-F
		115	800	11,600	18 cc	15,000	1030	M16x1.5 HP-F
	Double acting	180	1.245	17,910	11,3 cc	25,000	1720	M16x1.5 HP-F
		2.5	18	260	1570 cc	tba		1/2" NPT-F
		5	35	510	770 cc	tba		1/2" NPT-F
		10	70	1,015	400 cc	1500	1500	1/2" NPT-F
		15	115	1,670	250 cc	tba		1/4" NPT-F
		30	200	2,900	140 cc	4000	275	1/4" NPT-F
		40	285	4,130	100 cc	6000	410	M16x1.5 HP-F
		65	445	6,450	60 cc	10,000	690	M16x1.5 HP-F
115	800	11,600	36 cc	15,000	1030	M16x1.5 HP-F		
180	1.245	17,910	22,6 cc	25,000	1720	M16x1.5 HP-F		

PORTABLE HIGH PRESSURE GAS BOOSTER PACK

type RBS

RBS 160 booster

* tba = to be advised

Booster	Flow type	Ratio	Max. outlet pressure		Stroke volume	Gauge range (Dual scale)		HP outlet connection
			bar	psi		psi	psi	
160	Two stage	2.5-5	18	260	785 cc	tba		1/2" NPT-F
		5-15	115	1,670	365 cc	tba		1/2" NPT-F
		5-30	200	2,900	385 cc	4000	275	1/2" NPT-F
		15-30	250	3,625	125 cc	4000	275	1/4" NPT-F
		15-65	450	6,450	125 cc	10,000	690	1/4" NPT-F
		30-65	535	7,760	70 cc	10,000	690	1/4" NPT-F
		30-115	805	11,670	70 cc	15,000	1030	1/4" NPT-F
		30-180	1.250	18,125	70 cc	25,000	1720	1/4" NPT-F
		65-180	1.330	19,285	30 cc	25,000	1720	M16x1.5 HP-F

RBS 200 booster

* tba = to be advised

Booster	Flow type	Ratio	Max. outlet pressure		Stroke volume	Gauge range (Dual scale)		HP outlet connection
			bar	psi		bar	psi	
200	Double acting	2.5	18	260	2450 cc	tba		1/2" NPT-F
		4	28	405	1570 cc	tba		1/2" NPT-F
		8	55	795	770 cc	tba		1/2" NPT-F
		15	110	1,595	400 cc	tba		1/4" NPT-F
		25	175	2,540	250 cc	tba		1/4" NPT-F
		45	310	4,495	140 cc	6000	410	M16x1.5 HP-F
		65	445	6,450	100 cc	10,000	690	M16x1.5 HP-F
		100	695	10,080	60 cc	15,000	1030	M16x1.5 HP-F
	Two stage	2.5-4	45	650	1225 cc	tba		1/2" NPT-F
		4-15	115	1,670	785 cc	tba		1/2" NPT-F
		15-45	325	4,715	200 cc	6000	410	1/4" NPT-F
		15-65	450	6,450	200 cc	10,000	690	1/4" NPT-F
		25-65	485	7,030	125 cc	10,000	690	1/4" NPT-F
		25-100	710	10,295	125 cc	15,000	1030	1/4" NPT-F
		45-100	725	10,295	70 cc	15,000	1030	1/4" NPT-F
65-180	1.330	19,285	50 cc	25,000	1720	M16x1.5 HP-F		

PORTABLE HIGH PRESSURE GAS BOOSTER PACK

type RBS

OPTION ORDERING SYSTEM

RBS TYPE:	Pilot valve	Leak hole	Supply pressure regulator	Supply gauge
RBS-160-5-2-D-B	/HPV - high /LPV - low	/LH	/SPR /SPRBP - with by pass	/GSG
		Recorder	Pressure circuit	Atex
		/RCR-USB	/CPC400 - 400 bar /CPC700 - 700 bar	/EX

Order example: **RBS-160-5-2-D-B/LPV/EX**

OPTION TABLE

Recorder		Pilot valve	Leak hole	Supply pressure regulator	Supply gauge	Pressure circuit	Atex
pressure type	rev/hr						
BR = bar PR = psi	0 = 1/4-1hr 1 = 1 hr 4 = 4 hrs 8 = 8 hrs 24 = 24 hrs	HPV = high LPV = low	LH	SPR SPRBP = by pass	GSG	CPC400 = 400 bar CPC700 = 700 bar	EX

ACCESSORIES

TRANSPORTATION

Transportation

Removable pushbar with bracket for hose storage, see page 2 item 6

PORTABLE HIGH PRESSURE GAS BOOSTER PACK

type RBS

DIMENSIONS

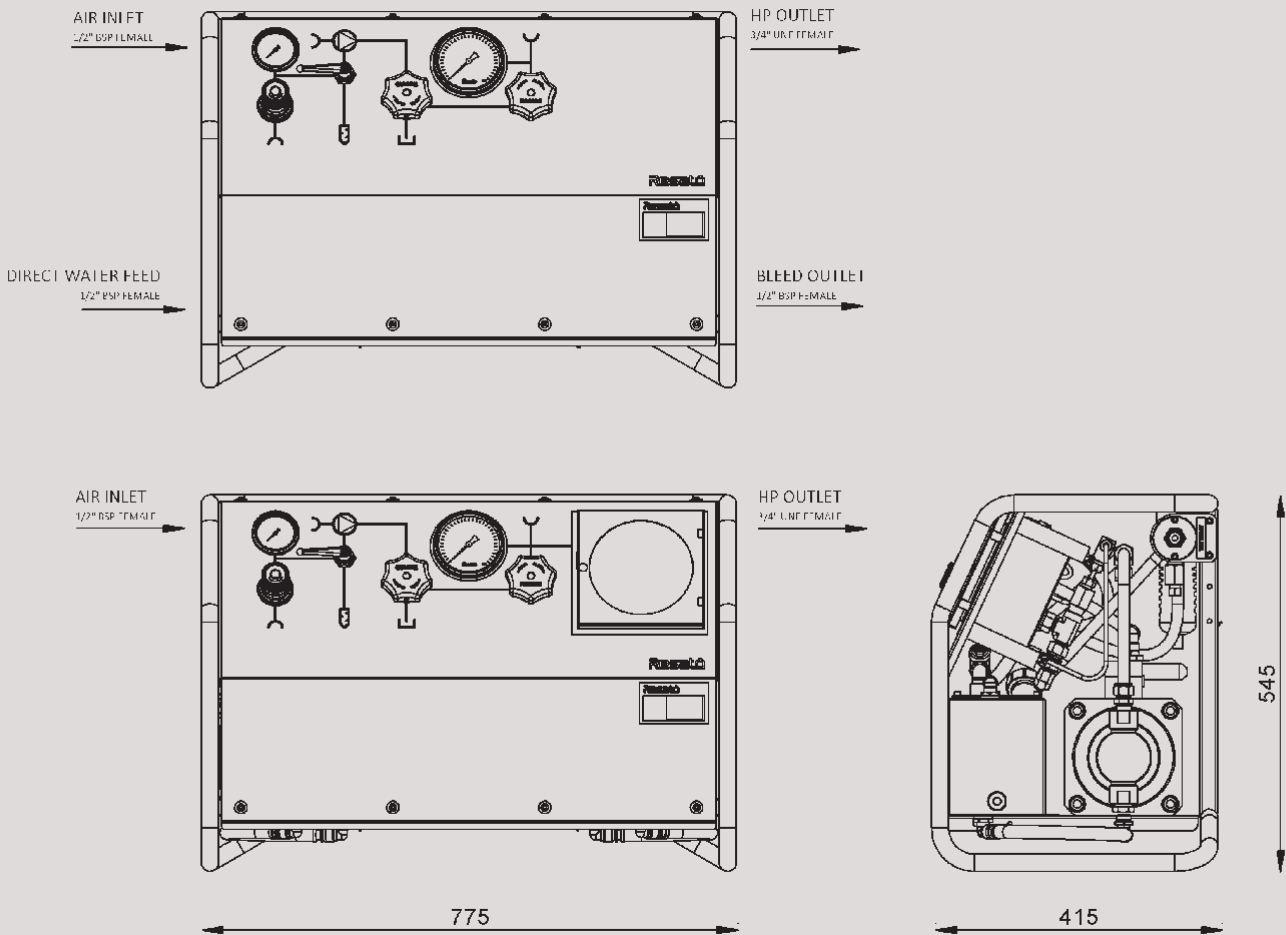

TECHNICAL SPECIFICATIONS

GENERAL

Net. Weight	Approx. 40 kg
Reservoir volume (optional)	17l
Legislation	2006/42/EG – Machinery Directive 94/9/EG – Atex Directive (optional)
Noise level	<94 dBA
De-air	1/2" BSP silencer
Ambient temperature	-20 - 60 °C

PORTABLE HIGH PRESSURE GAS BOOSTER PACK

type RBS

TECHNICAL SPECIFICATIONS

AIR

Consumption	Max 3Nm/3 min.
Connection	1/2" BSP Female
Maximum pressure	7 bar
Air*	Dry and filtered air. No lubrication.
Filtering degree	20 micron
Air quality standard	ISO 8573-1 Class 2.3.2.

HIGH PRESSURE CONNECTIONS

Outlet connection	1/2" NPT-F, 1/4" NPT-F or M16x1,5 HP-F
Gas supply connection (F1: P160 - 10/20/30 & P200 - 30) (F2: P160 - 40+ & P200 - 45+)	1/2" NPT-F, 1/4" NPT-F ,F1 (M16x1,5 HP-F) or F2 (M20x1,5 HP-F)

MEDIUM

Connection	1/2" BSP Female
Type**	Breathing air, nitrogen, argon, flammable gases
Cleanliness	ISO 4406 - 14/9
Viscosity	1,10 – 3 to 1 Pa.s
Temperature	-10 – 60 °C

* The booster has a lifetime lubrication. Once lubricated air is used lubrication will be needed for the lifetime of the system.

** For any other media please contact Resato for advice.

Resato International B.V.

📍 Duitlandlaan 1
9403 DL Assen - Holland

📬 P.O. Box 950
9400 AZ Assen - Holland

✉️ hpsales@resato.com
🌐 www.resato.com

☎️ +31 (0) 50 501 6877
☎️ +31 (0) 50 501 2402

V0.1 - Please note that general data and specifications given in this brochure are subject to change without notice.

Feel free to contact our sales department if you need more definite information.